

D6-370/DP

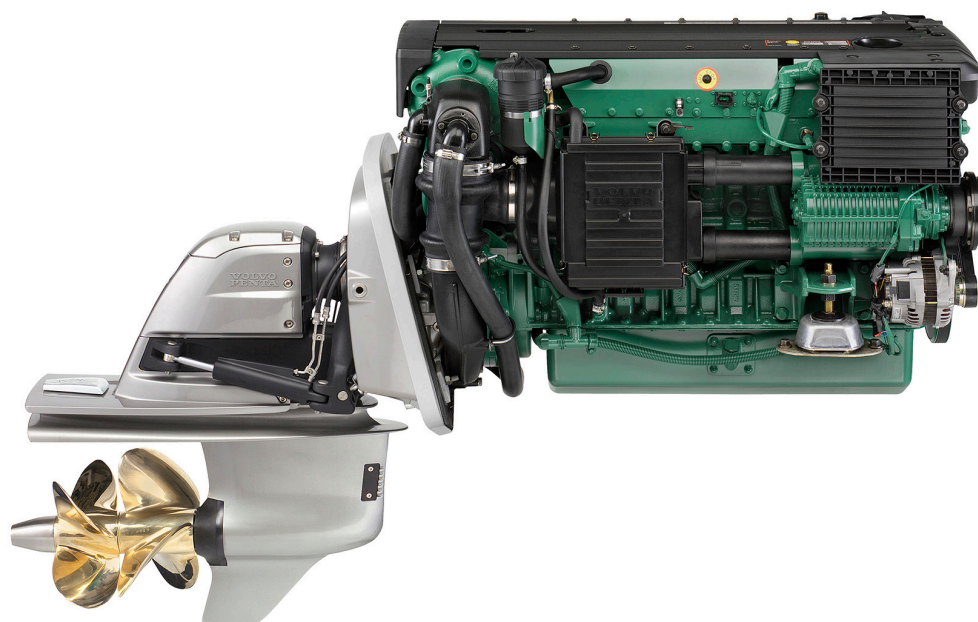

Technical Data

Engine designation	D6-370 A
Crankshaft power, kW (hp)	272 (370)
Propeller shaft power, kW (hp)	261 (355)
Engine speed, rpm	3500
Displacement, l (in ³)	5.5 (336)
Number of cylinders	6
Bore/stroke, mm (in.)	103/110 (4.06/4.33)
Compression ratio	17.5:1
Volvo Penta Duoprop drive	DPH
Ratio	1.63:1
Dry weight with DP, incl. prop. & PS, kg (lb)	770 (1698)
Rating	R5*
Emission compliance	IMO NO _x , EU RCD, US EPA Tier 3

Technical data according to ISO 8665. With fuel having an LHV of 42700 kJ/kg and density of 840 g/liter at 15 °C (60 °F).

Merchant fuel may differ from this specification which will influence engine power output and fuel consumption.

*RATING 5. For pleasure craft applications, and can be used for high speed planing crafts in commercial applications

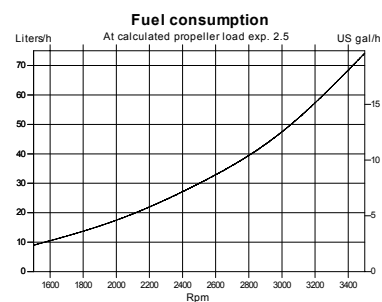
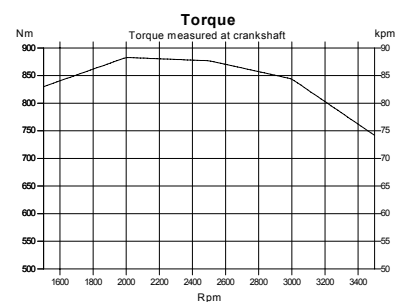
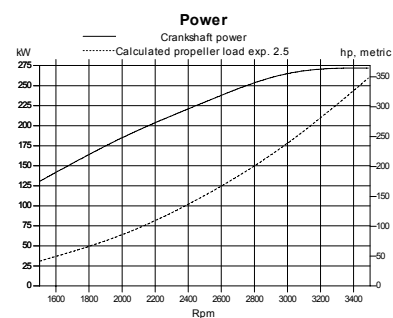

**VOLVO
PENTA**

D6-370/DP

Technical description:

Engine block and head

- Cylinder block and cylinder head made of cast-iron
- Ladder frame fitted to engine block
- 4-valve technology with hydraulic lash adjusters
- Double overhead camshafts
- Oil-cooled pistons with two compression rings and one oil scraper ring
- Integrated cylinder liners
- Replaceable valve seats
- Seven-bearing crankshaft
- Rear-end transmission

Engine mounting

- Flexible engine mounting

Lubrication system

- Easily replaceable separate full-flow and bypass oil filter
- Seawater-cooled tubular oil cooler

Fuel system

- Common rail fuel injection system
- Control unit for processing the injection
- Fine filter with water separator

Air inlet and exhaust system

- Belt-driven compressor with silencer of absorption type on both inlet and output port

- Air filter with replaceable insert
- Crankcase gases vented into the air inlet
- Exhaust elbow or exhaust riser
- Freshwater-cooled turbocharger
- Loss of sea water alarm

Cooling system

- Thermostatically regulated freshwater cooling
- Tubular heat exchanger with separate large volume expansion tank
- Coolant system prepared for hot water outlet
- Seawater strainer and easily accessible impeller pump

Electrical system

- 12V two-pole electrical system
- 115A marine alternator with Zener-diodes to protect the system from peak voltage, and integrated charging regulator with battery sensor cable for maximum use of alternator
- Fuses with automatic reset
- Auxiliary stop button

Instruments/control

- Complete instrumentation including e-key switch and interlocked alarm
- Digital Power Trim instrument with analog or digital reading

- EVC monitoring panels for single or twin installations
- Electronic shift and throttle
- Plug-in connectors

Drive

- Complete with transom shield, and installation components
- Max tilt angle 50° (adjustable)
- Protective zinc anodes to prevent corrosion
- Built-in kick-up function to reduce possible damage, in the event the drive strikes an underwater object
- Electrical shifting performed by electronic actuator
- Power Trim with one-button operation in twin installation
- Fully integrated water inlet and exhaust system
- Isolated propellers to prevent corrosion
- Fully hydraulic power-assisted steering system
- Optional electronic steering – prerequisite for Sterndrive Joystick. Twin installation only.

Option

U.S.C.G./MED (SOLAS) kit available.

Dimensions D6-370/DP

Not for installation

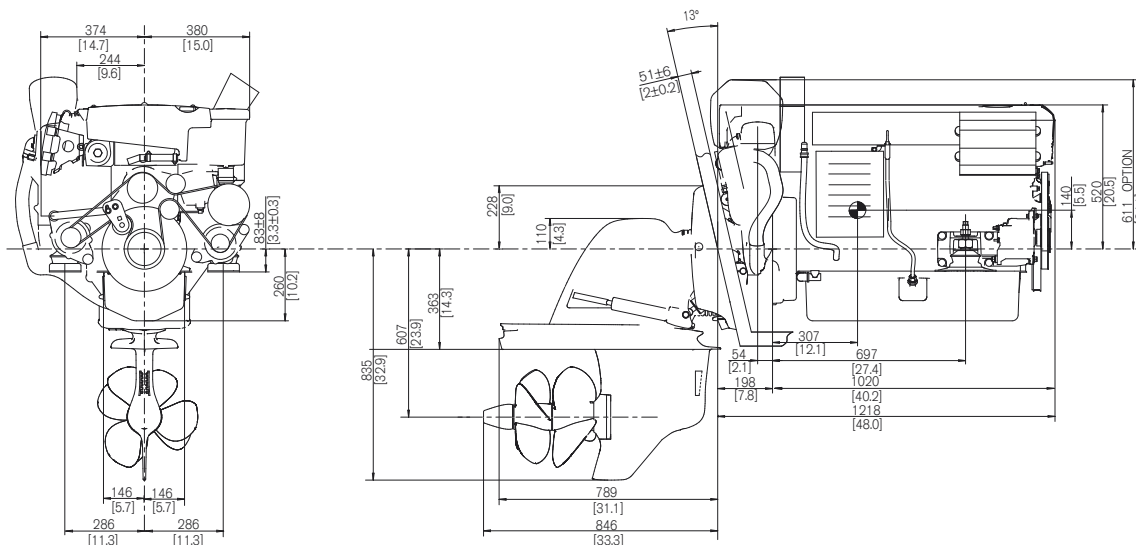

More information

Contact your nearest Volvo Penta dealer for more information about Volvo Penta engines and optional equipment/accessories or go to www.volvopenta.com



IOS



Android

Download the Volvo Penta dealer locator App for your iPhone or Android

VOLVO PENTA

AB Volvo Penta

SE-405 08 Göteborg, Sweden
www.volvopenta.com

Not all models, standard equipment and accessories are available in all countries. All specifications are subject to change without notice. The engine illustrated may not be entirely identical to production standard engines.